



CTS shown with optional napkin dispenser

The Elite 500 Tray or Plate Stand is a must to begin your line-up. It's versatile design provides a place for all the required utensils. Elite 500 units are compatible and will interlock with other Elite 500 units. This allows the units to be disconnected for cleaning under the serving line.

**STANDARD FEATURES**

- ◆ 14-gauge stainless steel top with 1-1/2" turndown on all sides
- ◆ Top secured by four recessed bolts
- ◆ 14-gauge stainless steel legs fastened to 18-gauge stainless steel bottom shelf
- ◆ 20-gauge stainless steel panels are attached to legs
- ◆ 5" diameter swivel plate casters, 2 with brakes
- ◆ Interlocking mechanism is provided to interlock with other Elite 500 units
- ◆ 6 plastic cylinders

JOB \_\_\_\_\_ ITEM # \_\_\_\_\_ QTY # \_\_\_\_\_

**MODEL NUMBER**

- CTS
- BPS

**DIMENSIONS**

- ◆ CTS - 36"H x 28"D x 32"L
- ◆ BPS - 36"H x 28"D x 39"L
- ◆ 36" height on all standard units
- ◆ 30" height is available on Petite Elite units
- ◆ 28" width
- ◆ 32" length for the CTS and 39" for the BPS

**CTS**

- ◆ Cutouts in the top for six silverware cups and an optional drop-in style napkin dispenser
- ◆ 20-gauge stainless steel inner shelf to accommodate a single stack of trays up to 15" x 20" with a capacity of up to 75 trays to the top of the unit

**BPS**

- ◆ Cutouts in the top for five silverware cups
- ◆ 20-gauge stainless steel end panels and two inner shelves to accommodate three stacks of 9" plates on each side with shelves sloped toward the center wall

**COMMON OPTIONS**

- Pizzazz powder Coating in lieu of Stainless steel**
- Napkin dispenser
- Legs in lieu of casters
- Stainless steel cylinders
- See reverse side for additional options.

**WARRANTY**

One year parts and labor. Warranty is detailed on inside front cover of the price list.

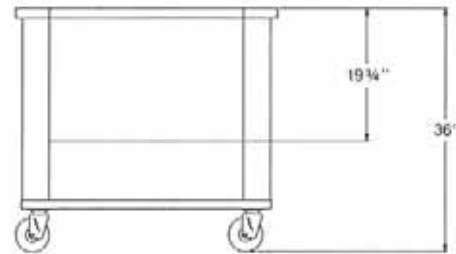
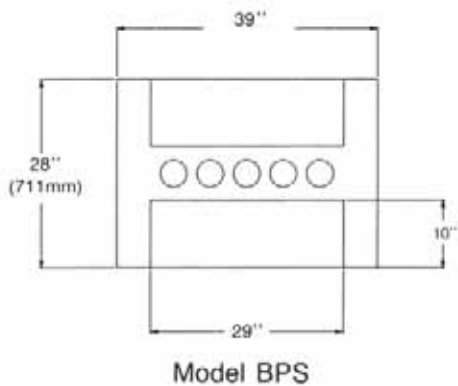
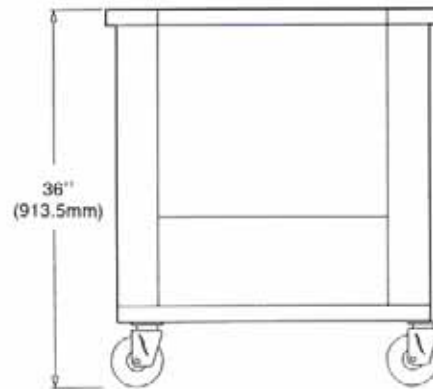
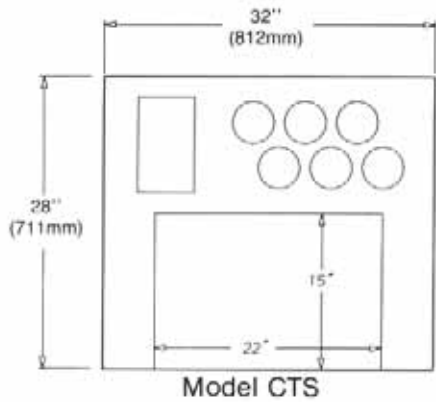

**OPTIONS / ACCESSORIES**

Part #	Description
<input type="checkbox"/> PPC	Pizzazz Powder Coating
<input type="checkbox"/> 0098241	Napkin Dispenser - hold napkins 6 -1/2" x 4-1/4" to 6 -1/2" x 5-1/4"
<input type="checkbox"/> 0098240	Napkin Dispenser for CTS ONLY - hold napkins 6-1/2" x 3-1/2"
<input type="checkbox"/> SSL	Legs in lieu of casters
<input type="checkbox"/> FRMA	Formica laminate finish
<input type="checkbox"/> SKR	Skirting

Note: Line-up drawing required when ordering false front, cashier stand or interconnected units.

**TRAY/PLATE STAND SPECIFICATIONS**

Model#	Length	Width	Height	Ship Wt. (lbs)
CTS	32"	28"	36"	160
BPS	39"	28"	36"	160

**A-12 SPEC**

**PIPER PRODUCTS**  
**BUILT TO LAST**  
[www.piperonline.net](http://www.piperonline.net)

300 S. 84th Avenue  
 Wausau, WI 54401  
 Phone: 800-544-3057  
 Fax: 715-842-3125

**LIMITED WARRANTY:** PIPER PRODUCTS warrants to the original purchaser parts and labor for a period of twelve (12) months from the date of purchase. See manufacturer's complete warranty for details.

It is our policy to build equipment which is design certified by companies that have been accredited at the Federal Level by the Occupational Safety and Health Agency (OSHA) and ANSI as a National Recognized Testing Laboratory. These companies include CSA International, Underwriters Laboratories, and the National Sanitation Foundation. However, a continuing program of product improvement makes it necessary to submit new models to the agencies as they are developed. Consequently, all models may not bear the appropriate labels at all times.

We reserve the right to change specifications and product design without notice. Such revisions do not entitle buyer to corresponding changes, improvements, additions or replacements for previously purchased equipment. Information is not for design purposes.